

### Benefits

- ▶ 9U 24" LED-backlit LCD display panel
- ▶ 1920 x 1200 **WUXGA** native resolution / 16.7M colors
- ▶ HDMI 1.4 + DVI-D + VGA video input
- ▶ PIP Sub-screen & PBP Dual-screen viewing efficiency
- ▶ 2-year standard warranty (upgradable up to 5 years)
- ▶ TAA Compliant

### Options

- DP 1.0 + HDMI 1.4 + Audio input & output ( **DP** )
- Composite + Audio IN ( **BNC** )
- 3G / HD / SD-SDI Broadcast-grade input ( **SDI** )
- MCS Multi display OSD controller ( **MCS** )
- MIL-type or lockable connector
- DC power : 12V / 24V / 48V / 125V / 250V
- IP65 front protection ( **IP65** )
- Touchscreen : Resistive 1-pt

## Product Specifications

Video	
Video input	HDMI 1.4 + DVI-D single link + VGA

Video Option		
Digital	Display port	DP 1.0 / HDCP 1.3
Analog	Composite ( BNC )	NTSC & PAL

LED-backlit LCD Panel	
Panel size ( diagonal )	24.1"
Native resolution	1920 x 1200
Brightness ( cd/m <sup>2</sup> )	300
Contrast ratio ( typ. )	1000 : 1
Colors	16.7 M
Viewing angle ( L/R/U/D )	89/89/89/89
Response time ( ms )	14
Dot pitch ( mm )	0.27
Display area ( mm )	518.4H x 324V
Surface treatment	Anti-glare, Hard-coating
Surface hardness	3H
Backlight type	LED
MTBF (hrs)	30,000

\* All dimensions stated are subject to change if options are selected / integrated to base model part codes

Physical		
Dimensions ( W x D x H )	Product	553 x 70 x 385 mm 21.8 x 2.8 x 15.2 inch
	Packing	530 x 645 x 155 mm 20.9 x 25.4 x 6.1 inch
Weight	Net	11.4 kg / 25.1 lb
	Gross	12.7 kg / 28 lb

Mounting	
Rackmount	9U
VESA mount	100*100 mm

## Diagrams ( mm )

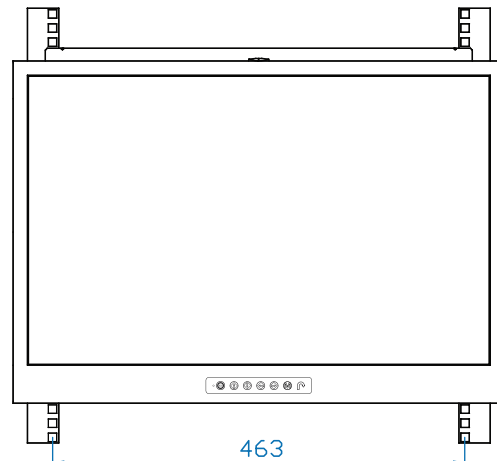
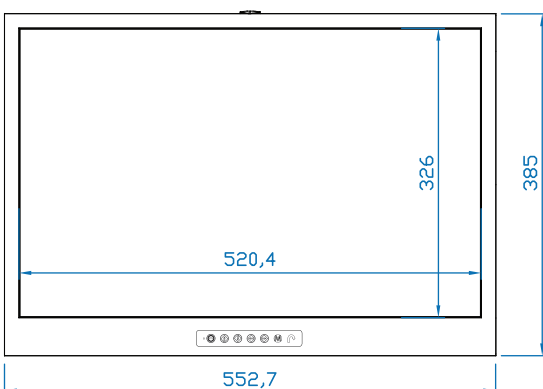

Audio Option		
Input	Connector	3.5mm stereo jack
	Impedance / Power level	30kΩ / 750mV
Output	Connector	3.5mm stereo jack
	Resistance / Power level	30kΩ / 2.8V
Speaker	Dual stereo	2W x 2

Power		
Input	Auto-sensing 100 to 240VAC, 50 / 60Hz	
Consumption	Screen on	Max. 33W
	Power saving mode	Max. 2W
	Power button off	Max. 1W

Environment	
Operating temp.	0 to 55°C degree
Storage temp.	-20 to 60°C degree
Operating humidity	10~90%, non-condensing
Storage humidity	5 ~90%, non-condensing
Operating altitude	16,000 ft
Non-operating altitude	40,000 ft
Shock	10G acceleration ( 11ms duration )
Vibration	10~300Hz 0.5G RMS random vibration

Compliance	
EMC	FCC & CE
Safety	CE / LVD & UKCA
Environment	REACH & RoHS3 / WEEE