

Front view

Rear view

Side view

577 [22.7"]

464 [18.3"]

450 [17.7"]

Side view(w/o side panel)

900 [35.4"]

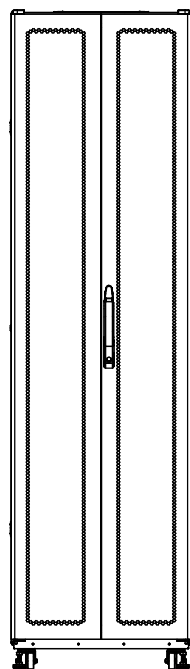
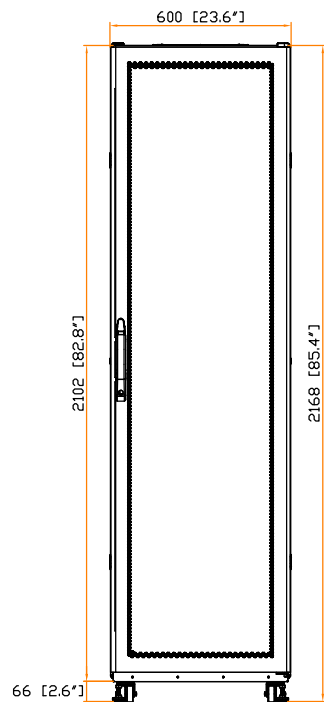

Front door

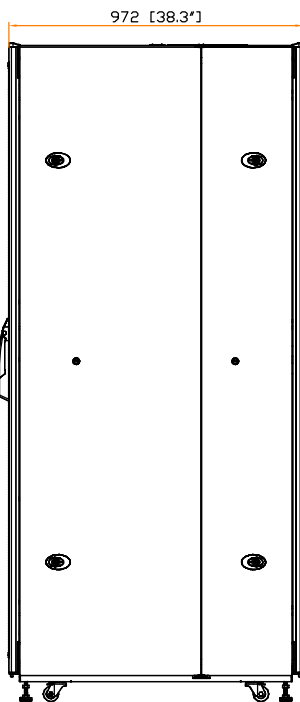

450 / 2000mm ( Effective Height )

Front view  
(w/o door)

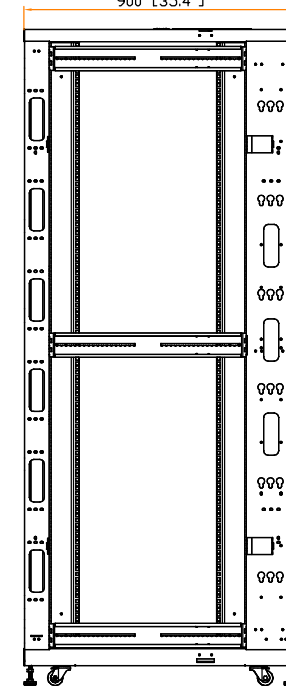
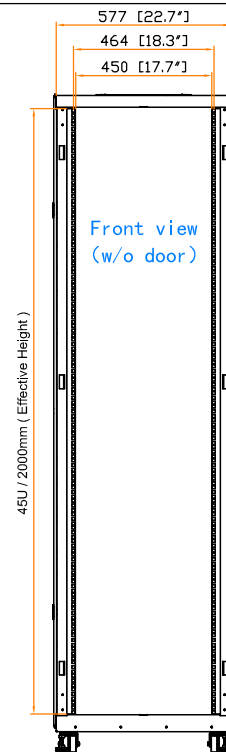

Top view

Bottom view

19" rail position

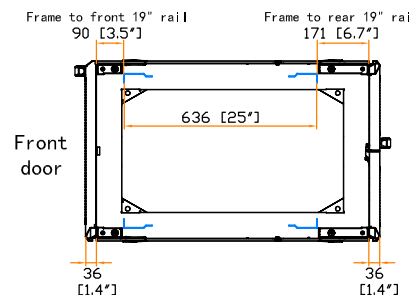
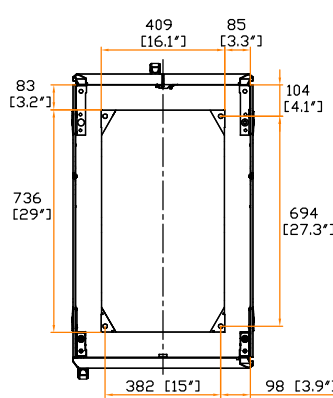
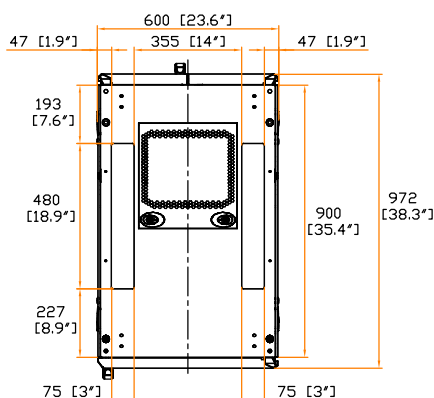

Front door

Front door



The company reserves the right to modify product specifications without prior notice and assumes no responsibility for any error which may appear in this publication.

Copyright 2020 Austin Hughes Electronics Ltd. All rights reserved.

Dimension (Overall) : 600 ( W ) x 972 ( D ) x 2168 ( H ) mm / 23.6 ( W ) x 38.3 ( D ) x 85.4 ( H ) in.

Dimension (Effective) : 577 ( W ) x 900 ( D ) x 2000 ( H ) mm / 22.7 ( W ) x 35.4 ( D ) x 78.7 ( H ) in.

Net Weight : - kg / - lb

Color : Black (RAL-9005) or White (RAL-9016)

Static Loading : 1500 kg / 3300 lb

Environmental : RoHS3 & REACH compliant by SGS

Unit : mm [ in. ]