

Extract Fan Door

- Remove heated air and prevent build-up of heated air inside the rack, which can cause equipment to overheat and shut down
- Provide a total of 1080 CFM peak exhaust airflow
- Front temp. LED w/ bundled temp. sensor x 1
- Fan ON / OFF by door switch for safety
- w/ handle lock
- Black or White color

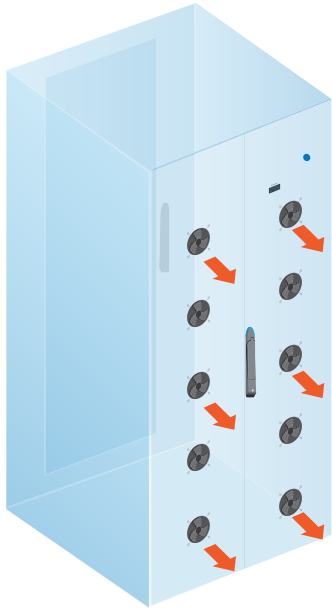

Part no. :
EXDS-47.8-VH

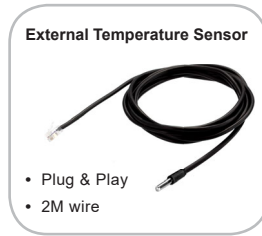

- Plug & Play
- 2M wire

Front view:

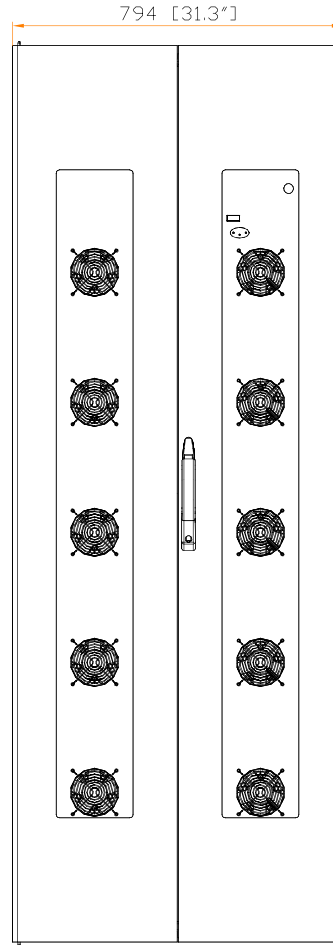

Rear view:

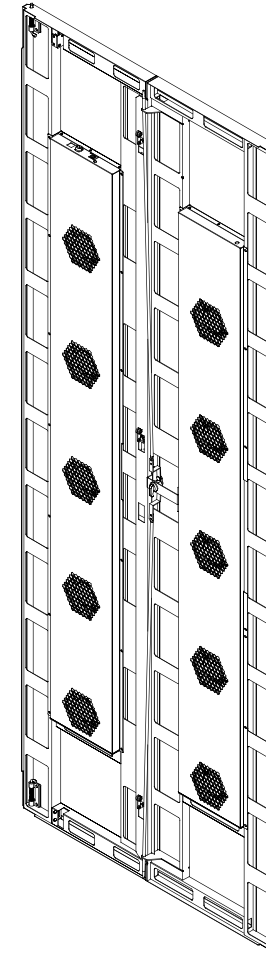

Side view:

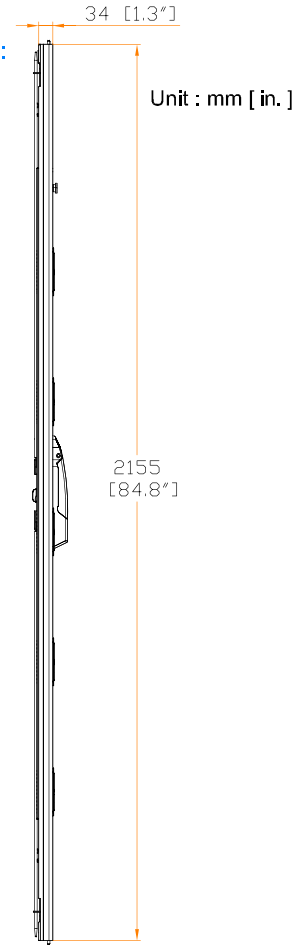

The company reserves the right to modify product specifications without prior notice and assumes no responsibility for any error which may appear in this publication.

Copyright 2021 Austin Hughes Electronics Ltd. All rights reserved.

Description	<ul style="list-style-type: none"> - Remove heated air and prevent build-up of heated air inside the rack, which can cause equipment to overheat and shut down - Provide a total of 1080 CFM peak exhaust airflow - Front temp. LED w/ bundled temp. sensor x 1 - Fan ON / OFF by door switch for safety - w/ handle lock
Fan size	: 120 (w) x 120 (H) X 25 (D) mm
Material	: Steel
Coating	: Powder
Color	: Black (RAL-9005) or White (RAL-9016)
Dimension	: 794 (W) x 2155 (H) x 34 (D) mm / 31.3 (W) x 84.8 (H) x 1.3 (D) in.
Gross weight	: - kg / - lb
Environmental	: RoHS3 & REACH compliant by SGS

