

**Vertical fibre management channel**

- 47U SR & NSR 800W rack
- Size : 90 x 1001.1 x 102.5
- Material : Steel / Plastic
- Positioned on the front or rear
- Set of 2

Part no. : FMC-47U



Front view:

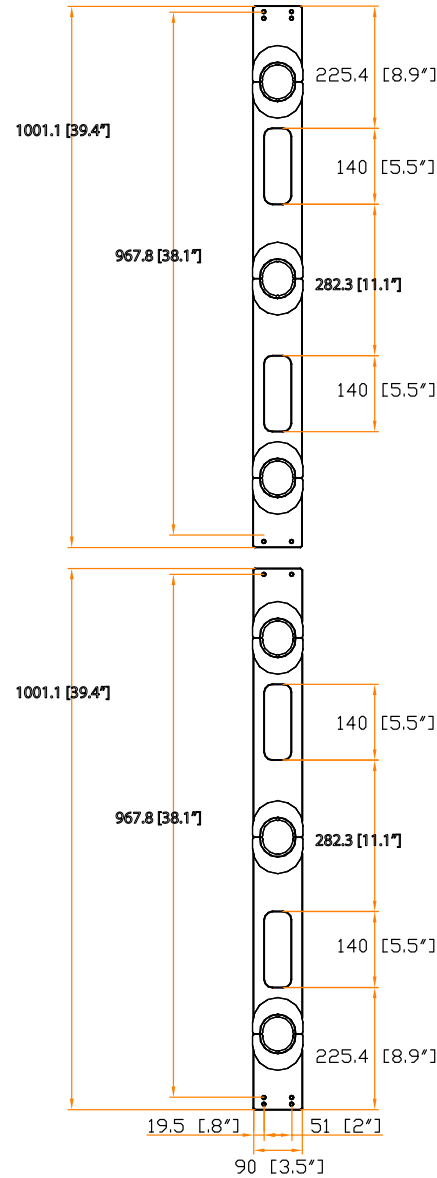

Top view:

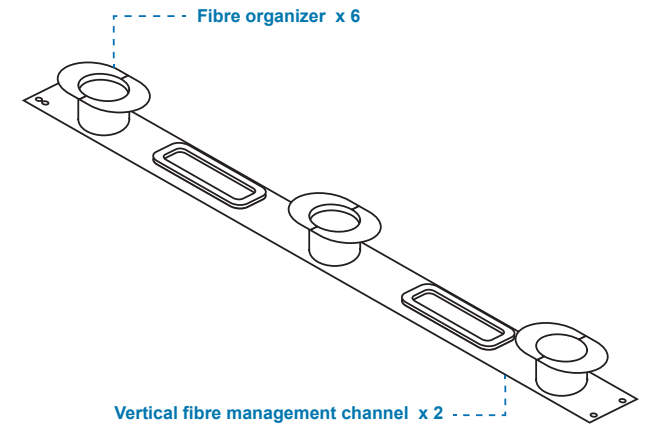
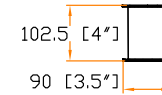

**Screw hardware set :**  
- M6 screw & nut x 8

unit : mm / in.

The company reserves the right to modify product specifications without prior notice and assumes no responsibility for any error which may appear in this publication.

Copyright 2020 Austin Hughes Electronics Ltd. All rights reserved.

Material	: Steel / Plastic
Coating	: Powder
Hardware set	: M6 screw & nut x 8
Dimension	: 90 (W) x 1001.1 (H) x 102.5 (D) mm / 3.5 (W) x 39.4 (H) x 40.4 (D) in.
Color	: Black (RAL-9005) or White (RAL-9016)
Gross weight	: 4 kg / 8.8 lb (pc)
Environmental	: RoHS2 & REACH compliant by SGS

