

SSK-45U
(SR Rack only)

Upper
Seal Kit

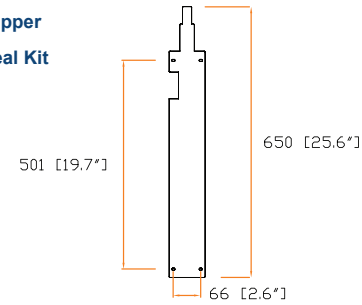

Middle
Seal Kit

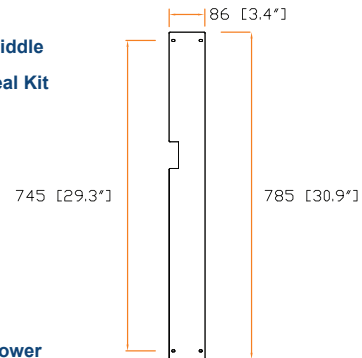

Lower
Seal Kit

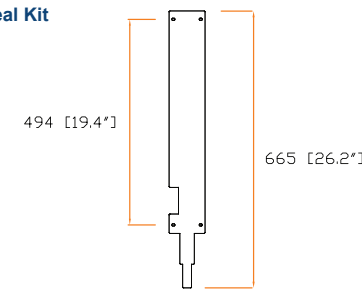

unit : mm / in.

The company reserves the right to modify product specifications without prior notice and assumes no responsibility for any error which may appear in this publication.

Copyright 2020 Austin Hughes Electronics Ltd. All rights reserved.

Description	: - Seal spacing between two bayed racks without side panels - Eliminate bypass air from front to rear - Designed for front only
Screw	: M5 Screw with nut x 12
Material	: Steel
Coating	: Powder
Dimension	: Upper : 86 (W) x 650 (H) mm / 3.4 (W) x 25.6 (H) Middle : 86 (W) x 785 (H) mm / 3.4 (W) x 30.9 (H) Lower : 86 (W) x 665 (H) mm / 3.4 (W) x 2.26 (H)
Color	: Black (RAL-9005) or White (RAL-9016)
Gross weight	: - kg / - lb
Environmental	: RoHS3 & REACH compliant by SGS