

Full Height Cable Tray, set of 2 sides

• Width : 75 mm

Part no. : CT-17U (17U)

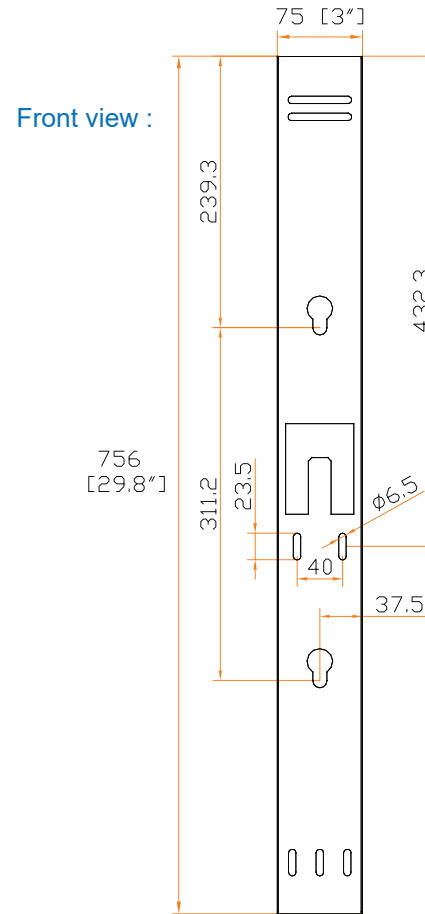

Top view :

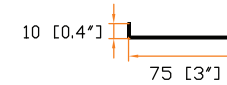

Detail view :

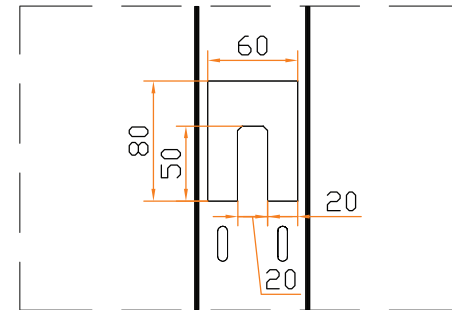

The company reserves the right to modify product specifications without prior notice and assumes no responsibility for any error which may appear in this publication.

Copyright 2020 Austin Hughes Electronics Ltd. All rights reserved.

Material : Steel
 Coating : Powder
 Dimension : 75 (W) x 756 (H) x 10 (D) mm / 3 (W) x 29.8 (H) x 0.4 (D) in.
 Color : Black (RAL-9005) or White (RAL-9016)
 Gross weight : - kg / - lb
 Environmental : RoHS3 & REACH compliant by SGS